

# STEEL DRUM FUNNEL - DF-S

APPROX WEIGHT: 10.04 lbs.  
DOES NOT INCLUDE WEIGHT OF POWER OR PACKAGING!!!

\*\*\*ANY ADDITIONS, DELETIONS, OR OMISSIONS MUST BE CORRECTED ON THIS DRAWING AS THIS DRAWING WILL BE CONSIDERED ALL INCLUSIVE\*\*\*

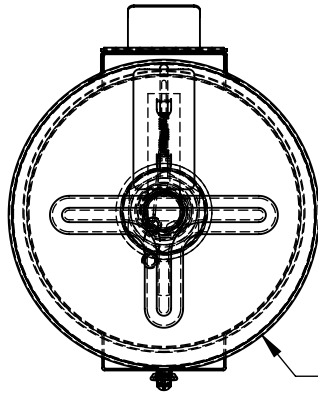

Ø 12 15/16"

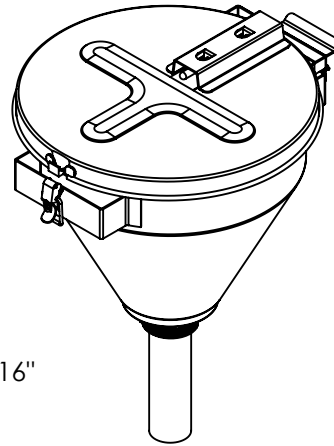

NOTE: LID OPENS AND CONTACTS THE PUSH-ROD. THE PUSH ROD MUST FORCE THE LID CLOSED IF THE FUSIBLE LINK MELTS.

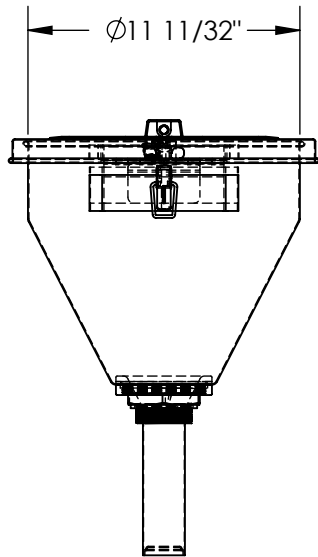

Ø 11 11/32"

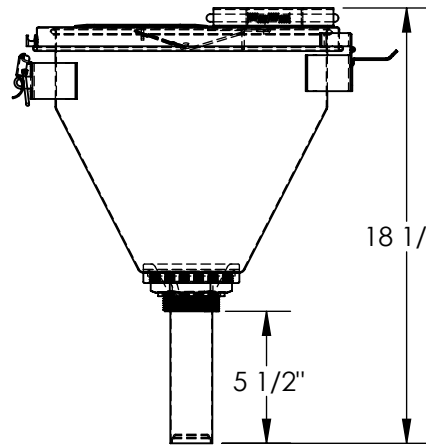

18 1/8"

5 1/2"

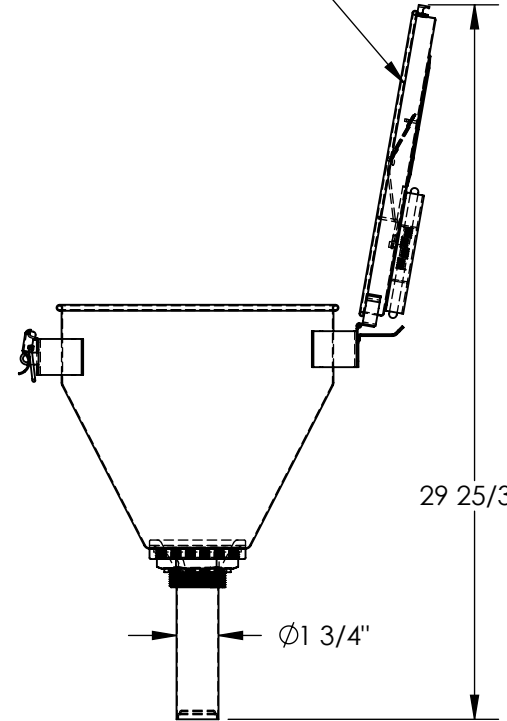

29 25/32"

Ø 1 3/4"

ALL GRAPHICS PROVIDED ARE FOR REFERENCE ONLY. IF CERTAIN DIMENSIONS ARE CRITICAL PLEASE VERIFY THOSE DIMENSIONS WITH YOUR SALESPERSON

## STANDARD FEATURES

- MODEL NUMBER IS: DF-S
- FITS 2" DRUM BUNGS
- DRUM SIZE IS 55 GALLONS
- OVERALL WIDTH IS: 12 15/16"
- OVERALL FUNNEL DIAMETER IS: 11 11/32"
- OVERALL HEIGHT (OPEN) IS: 29 25/32"
- OVERALL HEIGHT (CLOSED) IS: 18 1/8"
- SCREEN IS PERFORATED MESH WITH .04" HOLES
- INSIDE OF FUNNEL IS NOT PAINTED
- SOLDERS OF FUSIBLE LINK MELT AT 155°

## SPECIAL FEATURES

NONE

APPROVAL

I, THE UNDERSIGNED, AGREE THAT THE PRODUCT AS REPRESENTED SATISFIES DESIGN AND DIMENSION REQUIREMENTS. I ALSO ACKNOWLEDGE MY DUTY TO CONFIRM PRODUCT AND INSTALLATION COMPLIANCE WITH ALL APPLICABLE FEDERAL, STATE AND LOCAL REGULATIONS AND STANDARDS.

**ALL SPECIAL UNITS ARE NON-RETURNABLE**

As drawn       As marked

Signed: \_\_\_\_\_ Date: \_\_\_\_\_

LEAD TIME WILL START UPON RECEIPT OF SIGNED APPROVAL DRAWING

DISTRIBUTOR'S NAME:		P.O.#
VESTIL MANUFACTURING		X
DRAWN BY:		W.O.#
T. MOORE	DATE:	X
	06/04/09	SALES:
	SCALE: 1:8	X
REFERENCE:	QUOTE #	FILE NAME:
X	X	30-007-069